

81200CZ124
ADJUSTMENTS AND PARTS
SUPPLEMENT

CATALOG NO. K74718

02/19/09

3 THREAD
CARPET SERGER

SP457-2273

New Thread Stand for 81200
93065D3

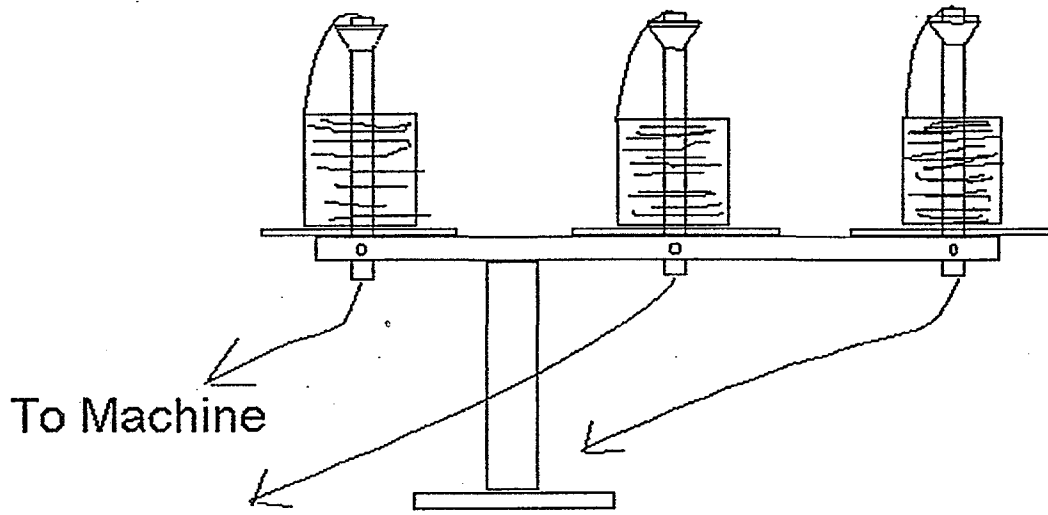

ADJUSTING INSTRUCTIONS

SETTING THE NEEDLE

Before adjusting the machine, insert a new needle into the needle bar as far as possible. The long groove of the needle must be directed to the operator. Tighten the needle clamp nut securely.

ADJUSTING THE LOOPER

For convenient access, remove the presser foot, throat plate and feed dog. Insert the looper into the looper rocker. Set the looper so that the distance from the centre line of the needle to the point of the looper is $7.1 \text{ mm} \approx 9/32''$ in the lowest position of needle bar just before moving upwards (Fig. 1). Therefore loosen the nut at right side of looper rocker and replace the ball stud till the specified dimension be obtained. As the looper moves to the right, its point should pass behind the needle as close as possible without contacting it. Adjustment can be made by loosening the fastening screws of looper rocker and replacing the looper rocker axially till this adjustment be obtained.

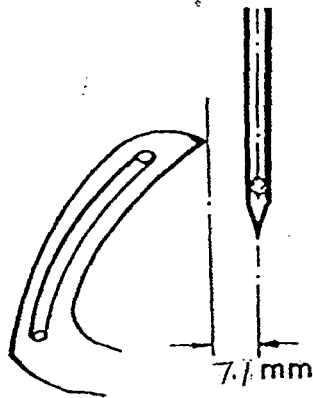

Fig. 1

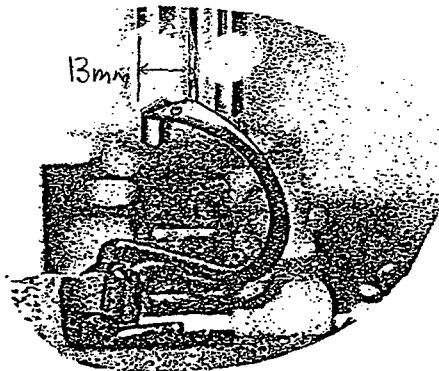

Fig. 2

ADJUSTING THE UPPER LOOPER

The spreader should closely pass behind the looper and behind the needle so that its point just brushes, without deflecting them. Set the distance of $13 \text{ mm} \pm 1 \text{ mm} \approx 1/2'' \pm 1/32''$ between looper tip and center of needle (Fig. 2).

NOTE : If adjustment front or back is necessary, loosen two screw (A) Fig.3, and move (A) spreader as required. Re-tighten two screws after adjustment.

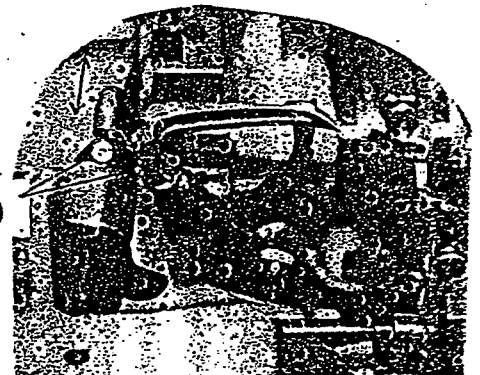

Fig.3

SETTING THE NEEDLE BAR HEIGHT

Set the needle bar so that the top of the needle eye is even with the underside of the looper, when the looper point in its travel to the right projects 1-1.5 mm = 0.04-0.06" from the right side of the needle. If adjustment is necessary loosen the clamping screw in the needle bar connection and move the needle bar up or down as required and retighten the screw.

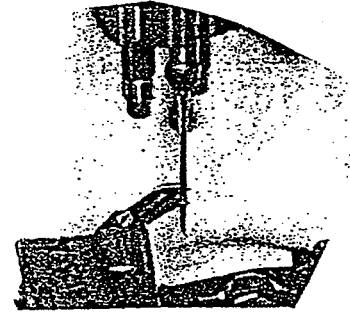

Fig. 4

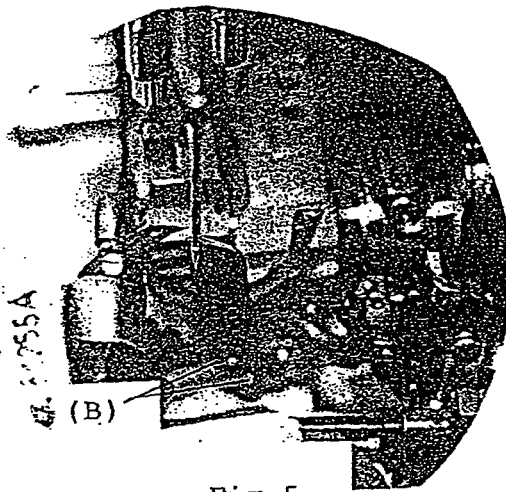

Fig. 5

SETTING THE REAR NEEDLE GUARD

Set the rear needle guard (Looper lever needle guard) so that it barely contacts the needle when the looper point approaches the left side of needle. Adjustment can be made by loosening the two screws (B) / Fig. 5 and re-set the needle guard at proper position.

NOTE: Change in stitch length will not require change in needle guard, but a change of needle size may require.

ADJUSTING THE FEED DOG

The height of the feed dog is correct, when at its highest point of travel, the rear teeth project above the throat plate their full depth. This can be accomplished by removing the feed dog holding screw and feed dog, then adjusting the stop screw in feed bar as required to maintain the prescribed setting. To adjust the feed dog within the throat plate, loosen the 2 bottom screws of the feed rocker and after adjusting as required retighten them.

NEEDLE THREAD TAKE UP

The setting of the needle thread take-up is correct when the needle thread is raised about 2 - 3 mm = 5/64 - 1/8" while the needle is descending.

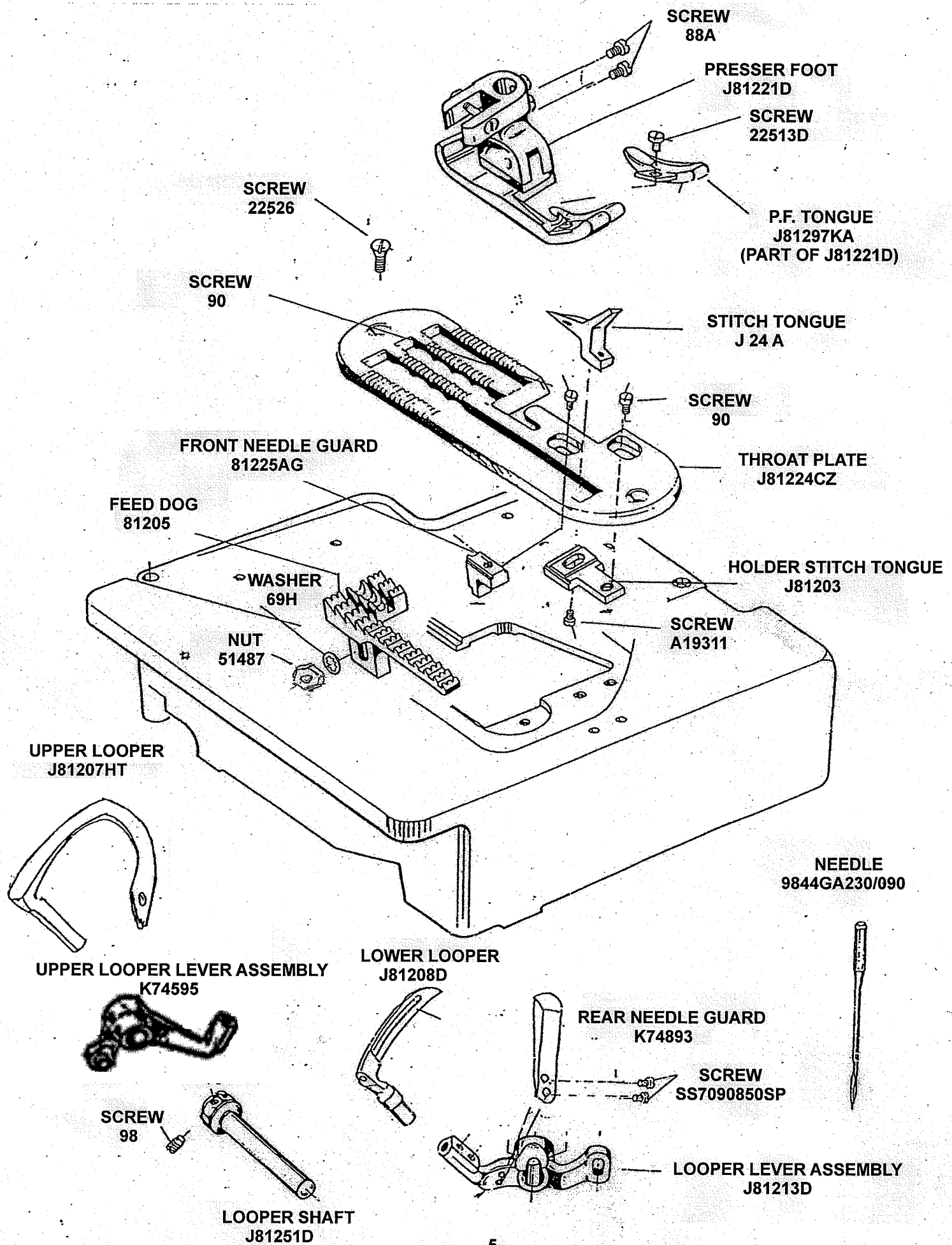

Corporate Office:

**Union Special Corporation
One Union Special Plaza
Huntley, IL 60142
Phone: 847•669•4500
Fax: 847•669•4454**

European Distribution Center:

**Union Special GmbH
Raiffeisenstrasse 3
D-71696 Möglingen, Germany
Tel: 49•07141•247•0
Fax: 49•7141•247•100**



Union Special
INDUSTRIAL SEWING EQUIPMENT